

Instructions for Use PCT (CLIA)

[Product Name]

PCT (CLIA)

[Packing Size]

60×1 Tests/Pkg (Calibrators included);

60×1 Tests/Pkg

[Intended Use]

This product is intended for use in quantitative determination of procalcitonin (PCT) in human serum, plasma, or whole blood. In clinical applications, it is mainly used for auxiliary diagnosis of bacterial infection. As the prohormone of calcitonin, PCT consists of 116 amino acids, and its molecular weight is about 12.8 kD. PCT is a type of glycoprotein that is not hormonally active, and it is also an endogenous non-steroidal anti-inflammatory substance. In case a patient is not infected, PCT is produced by thyroid. In case of systemic infection, especially bacterial infection, inflammatory response spurs various cells of many organs to secrete PCT. The metabolism of PCT rarely or never depends on renal functions. The clearance rate of PCT is not affected by kidney failure, and is not affected by steroid hormone either. In clinical diagnosis, PCT concentration of a patient suffering from sepsis increases in early phase, which facilitates early diagnosis and disease monitoring by doctors. According to literature and report, a systemic infection of human body generates PCT in blood circulation, it begins to increase within 2~4 hours and reaches the peak within 8~24 hours. PCT lasts for several days or several weeks. When PCT exceeds a threshold value, doctors had to consider the risk of severe sepsis and septic shock. PCT is an important marker that can specifically distinguish inflammatory response caused by bacterial infection from that caused by infection of other pathogens. Virus infection, allergic reaction, autoimmune disease, and transplant rejection do not cause obvious increase of PCT, but local bacterial infection can cause moderate increase of PCT. In some cases (neonate, multiple trauma, burn, major surgery, prolonged or severe cardiogenic shock), the increase of PCT may be irrelevant to infection. Generally in these cases, PCT can return to normal value quickly. Therefore, PCT is an ideal parameter for auxiliary diagnosis of severe bacterial infection, sepsis, and septicemia with high sensitivity and specificity.

[Principle of the Assay]

This assay adopts a double-antibody sandwich chemiluminescence immunoassay format. The test principle is as follows:

- (1) Add sample to magnetic microparticle coated with PCT antibody, and then mix with another acridinium-labeled PCT antibody in a reaction well. After incubation, PCT in the sample binds to both PCT antibodies, forming an immune complex.
- (2) After the reaction is complete, a magnet is used to capture the microparticle, unbound material is washed away. Then, add pre-trigger solution and trigger solution into the reaction mixture sequentially to initiate chemiluminescent reaction.
- (3) A photomultiplier tube is used to measure photons generated from the reaction. The count of photons is in direct proportion to PCT concentration in the sample. PCT concentration is derived from a built-in calibration curve.

[Main Components]

Component	Main Composition	Fill Volume	
		60 x 1 Tests/Pkg (Calibrators included)	60 x 1 Tests/Pkg
PCT reagent cartridge	Microparticle (R1): Magnetic microparticle coated with mouse anti-	60×50 μL	60×50 μL

	PCT monoclonal antibody, ~ 0.2g/L; Tris buffer, 50 mmol/L; ProClin 300, 0.5g/L		
	Conjugate (R2): Mouse anti-PCT monoclonal antibody labeled with acridinium, ~10 μg/L; MES buffer, 50mmol/L; ProClin 300, 0.5g/L	60×50 μL	60×50 μL
	Pre-trigger solution (R4): Acid solution containing 1.32% (w/v) hydrogen peroxide	60×100 μL	60×100 μL
PCT calibrator C0	Tris buffer solution, 25mmol/L; ProClin 300, 0.5g/L	1×1.0 mL	/
PCT calibrator C1	PCT (recombinant); Tris buffer solution, 25mmol/L; ProClin 300, 0.5g/L	1×1.0 mL	/
Reconstitution solvent	Purified water	1×1.0 mL	/
Calibration card	A card containing information of calibrator lot number and calibrator concentration	1 pcs	/

Note: Components in different lots of reagent cannot be mixed or exchanged for use.

Traceability: This test method can be traced back to Roche Elecsys BRAHMS PCT Assay.

After scanning the calibration card, you can check relevant calibrator information (calibrator lot No. and concentration) in the instrument.

The position of each component is shown in the front view (Upper) and vertical view (Down) of the reagent pack.

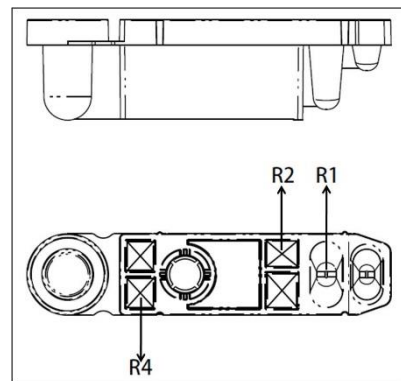

Instrument or material required but not provided (by Medcaptain):

- (1) Immu F6/Immu F6S Automated Chemiluminescence Immunoassay Analyzer;
- (2) Washing buffer;
- (3) Trigger solution;
- (4) Sample diluent;
- (5) 500 μL pipette tips;
- (6) PCT control.

[Storage Condition and Shelf Life]

Storage condition: Sealed and stored at 2~8 °C in an upright position. Avoid freeze-thaw cycle.

Shelf life: 14 months

Calibrator stability: If the calibrator is capped and stored at 2~8 °C and protected from light, its shelf life is 14 months. After calibrator C0 is uncapped, it is allowed to be stored for 1 day at room temperature (10~30 °C) and for 60 days at 2~8 °C. After calibrator C1 is uncapped and reconstituted, it is allowed to be stored for 1 day at room temperature (10~30 °C), 5 days at 2~8 °C, and 60 days at -20 °C (it is allowed to be frozen and thawed only one cycle).

Manufacturing and expiration dates can be found on reagent cartridge and package.

[Applicable Instrument]

Medcaptain Immu F6 Automated Chemiluminescence Immunoassay Analyzer

Medcaptain Immu F6S Automated Chemiluminescence Immunoassay Analyzer

[Sample Preparation]

- Serum samples, and plasma or whole blood samples collected by using a blood collection tube containing EDTA-K₂, EDTA-K₃, heparin lithium, or heparin sodium anticoagulant can all be used for the test.
- Volume of sample for each test: 30 µL.
- The collected sample should be tested as soon as possible.
- Whole blood must be analyzed within 4 hours after sample collection.
- Serum and plasma samples are allowed to be stored for 8 hours at room temperature (10~30 °C), 24 hours at 2~8 °C, and 30 days at -20 °C. A sample cannot be frozen and thawed multiple times. Only one freeze-thaw cycle is allowed. If a sample contains sediment or floccule, centrifuge the sample before the test.
- Blood collection tubes provided by different manufacturers are different in raw materials and additives, which may impact test results. Medcaptain has not validated all types of blood collection tubes that might be used for this assay. Each laboratory must make its own judgment about the feasibility of using certain brands of blood collection tubes.

[Test Procedure]

Reagent preparation

Reagent: PCT reagent cartridges (including microparticle R1, conjugate R2, and pre-trigger solution R4) is ready-to-use. The cartridge can be loaded on the instrument directly.

Calibrator: PCT calibrator C0 is liquid, and is ready-to-use. PCT calibrator C1 is lyophilized powder, and must be reconstituted before use: Pour the reconstitution solvent (1.0 mL/vial) into the bottle of PCT calibrator C1, cap the bottle, and wait for 10 min to reconstitute the calibrator. Gently shake the bottle several times until the calibrator is totally dissolved. Avoid air bubbles during the reconstitution process. After reconstitution, the calibrator can be split into aliquots, and stored under proper conditions for future use. The calibrator aliquot can be used only once.

Calibration

- Refer to the operation manual of Medcaptain Immu F6/F6S Automated Chemi-luminescence Immunoassay Analyzer for system calibration.
- Calibration must be performed at least once when a new lot of reagent is to be used.
- Use PCT assay kit and matched calibrators provided by Medcaptain for analyzer calibration.
- Before calibration, scan the calibration card provided in PCT kit to input the calibration curve and calibrator information.
- When performing calibration, take out reagent cartridge from the package, place it on reagent cartridge holder, push and close the door. Reagent-related information (reagent name, lot No., and expiration date) can be read automatically through a two-dimensional barcode on reagent cartridge.
- Put calibrators on a sample rack, and push the sample rack into the analyzer.
- Select **Reagent > Request Calib.** on the analyzer and select the corresponding assay and lot No. to request a calibration.
- Select the positions of calibrators on the sample rack, set the repeated

number of tests, and start calibration.

- Based on calibrator test results, analyzer system automatically checks the validity of the calibration curve, and makes adjustment to generate a calibration curve.
- Validity period of calibration: 28 days
- Renewed calibration is required in the following cases:
 - (1) Before using assay kits of a different lot;
 - (2) When control test result exceeds the specified limits;
 - (3) When the test kits of the same lot have been used on the instrument for over 28 days.
- For details about calibrator test, refer to the section about calibration in the operation manual of Medcaptain Immu F6/F6S Automated Chemiluminescence Immunoassay Analyzer.

Control test

- PCT control (manufactured by Medcaptain) have two levels: low-concentration PCT control (L) and high-concentration PCT control (H).
- These two-level controls should be tested in accordance with any local applicable regulations. Control testing is highly recommended every time the lot of reagent has been changed, the instrument needs to be re-calibrated, or after trouble shooting/ maintenance services.
- When performing the control test, take out the reagent cartridge from package, place it on reagent cartridge holder and close the door. Reagent-related information (reagent name, lot No., and expiration date) can be read automatically via a two-dimensional barcode on reagent cartridge.
- Put the controls on a sample rack, and push the sample rack into the analyzer.
- On the test request interface, choose “Control” as the test type and select the control lot No. and assay name for the control test.
- Press the start button to start the test. The control test results can be viewed after the test is finished.
- The control test results should fall within the defined limits. Otherwise, check the test system to identify the root cause, i.e., check the expiration date and storage condition of the controls, the analyzer performance and status. After eliminating the problems, test the controls again. If the test result still exceeds the range, please contact Medcaptain customer service immediately.
- Each laboratory is recommended to establish its own control intervals and limits based on its own conditions.
- For details about control test, refer to the section about control test in the operation manual of Medcaptain Immu F6/F6S Automated Chemiluminescence Immunoassay Analyzer.

Sample Test

- When performing the sample test, take out reagent cartridge, place it on reagent cartridge holder, and close the door. Reagent-related information (reagent name, lot No., and expiration date) can be read automatically via a two-dimensional barcode on the reagent cartridge.
- If a blood collection tube is used in the test, sample volume must be larger than 1.0 mL.
- Uncap the sample tubes, place samples on the sample rack, and push the sample rack into instrument.
- On the test request interface, choose “Sample” as the test type, enter sample information, and select PCT assay for the test.
- Press the start button to start the test. Test results can be viewed after the test is completed.
- Required volume for each reagent component: 50 µL of R1, 50 µL of R2, and 100 µL of R4 for each test. The analyzer automatically pipettes and mixes the sample and reagent, and incubate the mixture at 37 °C. The time from sample pipetting to test completion is about 15 min.
- For details about sample test, refer to the section about the sample test in the operation manual of Medcaptain Immu F6/F6S Automated Chemiluminescence Immunoassay Analyzer.

Calculation

Based on the lot-specific calibration curve, the instrument automatically

calculates the test results of each sample (unit: ng/mL).

Human beta-CGRP 10000 ng/mL <0.1%

[Reference Intervals]

Medcaptain determines the reference ranges by studying 200 samples from healthy people.

Number of Samples (n)	95th percentile (ng/mL)
200	0.050

The 200 samples are collected from people aged 13~87, 107 samples are collected from male, and 93 samples are collected from female. All the participants are healthy individuals. In the last month, they have not suffered from a disease (including inflammation, bacterial infection, and sunstroke), trauma, or surgery, and have not taken medicines. Besides, they are not suffering from chronic inflammation or autoimmune disease, they have never suffered from cardiovascular disease, and none of the female participants are pregnant or in lactation period.

Due to differences in geographic region, race, gender, and age, it is highly recommended for each laboratory to establish its own reference intervals.

[Interpretation of Results]

- The test results from this assay kit can only be used as assistance for clinical decision. Clinical symptoms, medical history, other laboratory test results, and therapeutic response must be combined in a comprehensive manner for confirming the diagnosis or ruling out the possibility of a disease.
- The measurement range of this assay kit is 0.02~100 ng/mL. If the PCT concentration in a sample is lower than the limit of detection (LoD), the value reported is “<0.02 ng/mL”. If the PCT concentration in a sample is higher than the upper limit of measurement, the value reported is “>100 ng/mL”.
- For a sample with PCT concentration over 100 ng/mL, it is recommended to manually dilute the sample using sample diluent (the recommended dilution rate is 1:4), and perform the test again to obtain an accurate result.
- When the instrument displays “SMPL”, the sample is insufficient. In this case, prepare sufficient sample for the test again. When the instrument displays “SMPJ”, clot detected in sample. In this case, remove the clot in sample and perform the test again.
- Some test results may contain identification symbols. For details about the identification symbols, refer to the section about result identification in the operation manual of Medcaptain F6/F6S Chemiluminescence Immunoassay Analyzer.

[Limitation]

- The test results obtained by using this assay kit can only be used for clinical reference. It cannot be used as the only basis for confirming or ruling out a disease.
- No Hook effect occurs for PCT concentration lower than 3000 ng/mL.
- When concentration of endogenous interfering substance is lower than the value listed in the table below, relative deviation of the measurement value caused by interference will not exceed 10%.

Potential Endogenous Interfering Substance	Potential Interfering Substance Concentration
Total protein	≤12 g/dL
Bilirubin	≤25 mg/dL
Hemoglobin	≤1000 mg/dL
Triglyceride	≤1500 mg/dL

- When concentration of potential cross-reacting substance is lower than the concentration listed in the table below, the cross reaction rate is lower than 0.1%.

Potential Cross-reacting Substance	Concentration	Cross Reaction Rate
Human calcitonin	10 ng/mL	<0.1%
Human katalcalcin	30 ng/mL	<0.1%
Human alpha-CGRP	10000 ng/mL	<0.1%

- In addition to pathogen infection, PCT level may also arise in the following cases:
 - (1) Long-time or severe heart shock;
 - (2) Long-term severe irregular organ perfusion;
 - (3) Early-stage extensive trauma, surgery, and severe burn;
 - (4) Inflammatory cell factor stimulation and release treatments;
 - (5) Neonate (within 48 hours after being born).
- Heterophilic antibody and rheumatoid factor (RF) in human blood can react with immunoglobulin in the reagent, which will impact assay results. Consequently, abnormal value may be observed in the test. For this reason, other clinical information must be combined with the test results to make a comprehensive decision.
- RF with a concentration lower than 1500 IU/mL does not have any obvious impact on test results.
- PCT reagent contains monoclonal antibodies originated from mouse. Some patients who have received monoclonal mouse antibody treatment or diagnosis may contain human anti-mouse antibody (HAMA), and test results of these patients may be falsely elevated or reduced. This assay kit contains anti-interference ingredient, which can effectively reduce HAMA interference, but the problem may not be totally eliminated, and some sample testing may still be impacted.

[Product Characteristics]

1 Appearance

Package of the assay kit should be intact without any damage, with all components packed in the kit. The appearance is clean and tidy, the label is clear, and no liquid leakage can be found.

2 Fill Volume

No.	Component	Fill Volume
1	Magnetic microparticle coated with PCT antibody(R1)	50 μL±5 μL
2	Acridinium labeled PCT antibody conjugate (R2)	≥50 μL
3	Pre-trigger solution (R4)	≥100 μL

3 Limit of Blank (LoB)

LoB ≤ 0.01ng/mL

4 Limit of Detection (LoD)

LoD ≤ 0.02ng/mL

5 Accuracy

Spike PCT of a known concentration into samples at different levels. Spiking recovery should be 100% ±10%.

6 Linearity

Test PCT samples with concentration in the range of 0.03~100 ng/mL. Linear correlation coefficient r ≥ 0.990.

7 Repeatability

Test two enterprise reference samples with PCT concentration of (0.5±0.1) ng/mL and (10±1) ng/mL repeatedly. The coefficient of variation (CV) of test results for both reference samples must be less than 8.0%.

8 Batch-to-Batch Variation

Use three batches of assay kit to test two enterprise reference samples with PCT concentration of (0.5±0.1) ng/mL and (10±1) ng/mL repeatedly. CV for three batches of assay kit must be less than 10.0%.

9 Appearance of Calibrator

- (1) Package of calibrators and reconstitution solvent should be intact without any damage. The appearance is clean and tidy, the label is clear, and no liquid leakage can be found.
- (2) Calibrator C0 and reconstitution solvent should be clear and transparent liquid without any sediments, insoluble particles, or floccules.
- (3) Calibrator C1 should be white or faint yellow freeze-dried powder with no dent or trace of liquid. After being reconstituted, calibrator C1 should be homogeneous liquid without any visible particles or sediments.

10 Fill Volume of Calibrator

- (1) The fill volume of calibrator C0 is no less than the volume printed on the label (1.0mL).

(2) The fill volume of reconstitution solvent must be in the range as shown on the label (1.0mL±10.0%).

11 Accuracy of Assigned Value

Use the working calibrator with value assigned using a higher-level measurement procedure to calibrate the chemiluminescence immunoassay system. Afterwards, use the same lot of assay kit to measure the value of each calibrator. The deviation between measurement value and t assigned value does not exceed ±10.0%.

12 Homogeneity of Calibrator

12.1 Within-bottle Homogeneity

Standard deviation (SD) is used to evaluate the within-bottle homogeneity of calibrator C0, which should be less than 0.02 ng/mL. CV is used to evaluate the within-bottle homogeneity of calibrator C1, which should be less than 8.0%.











12.2 Between-bottle Homogeneity



Standard deviation (SD) is used to evaluate the between-bottle homogeneity of calibrator C0, which should be less than 0.02 ng/mL. CV is used to evaluate the between-bottle homogeneity of calibrator C1, which should be less than 5.0%.

[Precautions]

- 1 This product is for IVD use only.
- 2 This product is intended to be used by professionals only.
- 3 Do not use the product beyond its expiration date.
- 4 Do not pool reagents from different kits, or from different reagent lots.
- 5 Due to difference in antibody specificity systems of different manufacturers may derive different results for the same sample. Test results obtained from different systems may not be comparable, and should not be correlated to each other in clinical interpretation.
- 6 Do not vehemently shake reagent components to avoid bubble generation.
- 7 During use of this product, perform tests by strictly following operation procedures as written in the package insert and guidelines set up by each laboratory.
- 8 The test results from this assay can only be used as auxiliary evidence for clinical decision. Clinical symptoms, medical history, other laboratory test results, and therapeutic response must be combined in a comprehensive manner for patient management.
- 9 Lab operator must wear suitable gloves when using the product. In case of accidental exposure to the reagent, flush the body part with large volume of water immediately. If reagent splashes into eyes, flush eyes with copious of water and consult a doctor immediately.
- 10 All samples and reaction waste must be considered potentially biohazards and be handled in accordance with the local laws and regulations.
- 11 Do not reuse a reagent cartridge. It is designed for single use only.
- 12 Put left-over reagent cartridge into 2~8 °C refrigerator, rather than leaving them on the instrument.

[Symbol Description]

	Temperature limit		Date of manufacture
	<i>In vitro</i> diagnostic medical device		Catalogue number
	Batch code		Consult instructions for use
	Use-by date		Authorized representative in the European Community/European Union
	This way up		CE marking of conformity

	Manufacturer		Unique device identifier
	Biological risks		

[References]

- [1] Expert consensus team for PCT emergency clinical application, Expert consensus on PCT emergency clinical application, Chinese Journal of Emergency Medicine, 2012, 21(9): 944-951.
- [2] Gendrel D, Bohuon C. Procalcitonin as a marker of bacterial infection. *Pediatr Infect Dis J* 2000, 19: 679-688.
- [3] Rey C, Los Arcos M, Concha A, et al. Procalcitonin and C-reactive protein as markers of systemic inflammatory response syndrome in critically ill children. *Intensive Care Med* 2007, 33: 477-484.
- [4] Whang K T, Vath S D, Becker K L, et al. Procalcitonin and Pro-inflammatory cytokine interactions in sepsis. *Shock* 2000, 14(1): 73-38.
- [5] Christ-Crain M, et al. Effect of procalcitonin-guided treatment on antibiotic use and outcome in lower respiratory tract infections: cluster-randomized single blinded intervention trial. *Lancet* 2004, 363(9409): 600-607.
- [6] Christ-Crain M, Muller B. Procalcitonin in bacterial infections-hype, hope, more or less? *Swiss Med Wkly* 2005, 135(31-32): 451-60.
- [7] Hausfater P, Juillien G, Madonna-Py B, et al. Serum procalcitonin measurement as diagnostic and prognostic marker in febrile adult patients presenting to the emergency department. *Crit Care* 2007, 11(3): 60-69.
- [8] Meisner M. Procalcitonin (PCT)-A new innovative infection parameter. *Biochemical and clinical aspects*. Thieme Stuttgart, New York 2000, ISBN: 3-13-105503-0.
- [9] Chiesa C, Panero A, Rossi N, et al. Reliability of Procalcitonin Concentrations for the Diagnosis of Sepsis in Critically ill neonates. *Clin Infect Dis* 1998, 26: 664-672.
- [10] American College of Chest Physicians /Society of Critical Care Medicine. Definitions for sepsis and organ failure and guidelines for the use of innovative therapies in sepsis. *Crit Care Med* 1992, 20: 864-874.

[Basic Information]



MEDCAPTAIN MEDICAL TECHNOLOGY CO., LTD.
12th Floor, Baiwang Research Building, No. 5158 Shahe West Road, Xili, Nanshan, 518055 Shenzhen, Guangdong, PEOPLE'S REPUBLIC OF CHINA

Telephone: +86-755-26953369
Website: <http://www.medcaptain.com>



Post-sales service: MEDCAPTAIN MEDICAL TECHNOLOGY CO., LTD.
Telephone: +86-755-26953369
Postal code: 518055

Manufacturing Location: Building C, Jiale Science and Technology Industrial Park, Matian Street, Guangming, 518106 Shenzhen, Guangdong, PEOPLE'S REPUBLIC OF CHINA



R Sight B.V.
Roald Dahliaan 47, 5629 MC, Eindhoven. The Netherlands

[Issued on]

Sep., 18, 2024